

# Trampoline

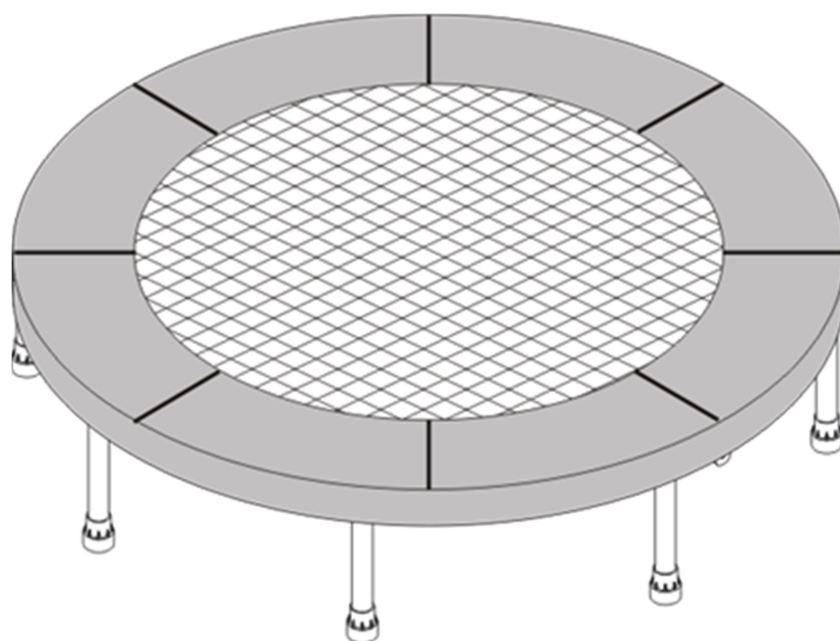

**OWNER'S MANUAL**

## Thank you for purchasing our product

**IN CASE OF MISSING OR BROKEN PARTS, PLEASE CONTACT PLACE OF PURCHASE FOR ASSISTANCE.**

### **BOUNCE SAFELY ON YOUR TRAMPOLINE**

 <b>WARNING</b>
Misuse and abuse of this trampoline is dangerous and can cause serious injury or death

1. DO NOT attempt or allow somersaults. Landing on the head or neck can cause serious injury, paralysis, or death, even when landing in the middle of the mat.
2. DO not allow more than one person on the trampoline at any one time. Use by more than one person at the same time can result in serious injuries.
3. Use the trampoline only with mature, adult knowledgeable supervision.
4. Trampolines over 20 in. (51cm) tall are not recommended for use by children under 6 years of age.
5. Inspect the trampoline before each use. Make sure the frame Pad is correctly and securely positioned. Replace any worn, defective, or missing parts.
6. Climb on and off the trampoline. Do not jump from the trampoline to the floor or ground when dismounting, or onto the trampoline when mounting. Do not use the trampoline as a springboard to other objects.
7. Stop bounce by flexing knees as feet come in contact with the trampoline mat. Learn this skill before attempting others.
8. Learn fundamental bounces and body positions thoroughly before trying more advanced maneuvers. A variety of trampoline maneuvers can be carried out by performing the basic fundamentals in different combinations, performing one fundamental after another, with or without feet bounces between them. Refer to the Bouncing Basic section in this manual.exercise aids in determining heart rate trends in general.
9. Avoid bouncing too high. Stay low until bounce control and repeated landing in the center of the trampoline has been achieved. Control is more important than height.
10. While bouncing, keep head up and facing forward with eyes focused on the perimeter of the trampoline. This will help control balance.
11. Do not bounce when tired or for prolonged periods.
12. Secure the trampoline correctly when not in use and prevent unauthorized use. If a trampoline ladder is used, remove it from the trampoline when leaving the area to prevent unsupervised access by

children under 6 years of age.

13. Maintain a clear area around the trampoline and remove objects which could obstruct the user.
14. Do not use the trampoline while under the influence of alcohol or drugs.
15. For information about skills & training, contact a certified trampoline instructor.
16. Bounce only when the mat is dry. The trampoline must not be used in windy conditions.
17. Read all instructions before using the trampoline. Warnings and instructions for the care, maintenance, and use of this trampoline are included to promote safe, enjoyable use of this equipment.

- **DO NOT** wear hare-soled shoes as they cause excessive wear to the mat.
- **DO NOT** wear jewelry, hooks, buttons, or other protrusions that might get caught on the mat.

**Bounce in center of the mat.**  
**SAVE THESE INSTRUCTIONS - THINK SAFETY!**

## Installation

1. Ensure adequate overhead clearance. A minimum of 26 feet (8 meters) from ground level is recommended. Provide clearance for wires, tree branches, and other possible hazards.
2. Ensure adequate lateral clearance. Place the trampoline away from walls, structures, fences, swimming pools, and other play areas. Maintain a clear space on all sides of the trampoline.
3. Place the trampoline on a level surface before use.
4. Use the trampoline in a well-lighted area. Artificial illumination may be required for shady areas.
5. Secure the trampoline against unauthorized and unsupervised use.
6. Remove any obstructions from beneath the trampoline.
7. The owner and supervisors of the trampoline are responsible to making all users aware of practices specified in the instructions.

## INTRODUCTION

**Before using this trampoline, please read all information**

**provided in this manual carefully.** To reduce the risk of injury, please follow appropriate safety rules and tips.

- ⊗ Misuse and abuse of this trampoline is dangerous and can result in serious injury!
- ⊗ Inspect the trampoline before each use for wear and tear, loose or missing parts.
- ⊗ Assembly, care and maintenance of product, safety tips, warnings, and proper techniques in jumping and bouncing are all included in this manual.
- ⊗ All users and supervisors must read and familiarize themselves with these instructions.
- ⊗ All users must be aware of their own limitations when performing jumps and bounces with this trampoline.
- ⊗ For family domestic use only.
- ⊗ The safety net shall be equipped if the length/diameter/diagonals of the frame greater than 2.5m.

# warning

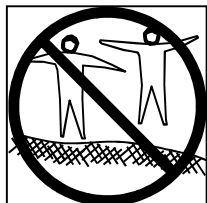

NO MORE THAN ONE PERSON AT A TIME ON THE TRAMPOLINE!  
 MULTIPLE JUMPERS INCREASE THE RISK OF INJURY SUCH AS  
 BROKEN NECK, LEG, BACK OR HEAD INJURY.  
 DO NOT PERFORM SOMERSAULTS (FLIPS) AS THIS WILL  
 INCREASE RISK OF LANDING ON HEAD OR NECK RESULTING IN  
 INCREASED RISK OF SERIOUS INJURY OR DEATH

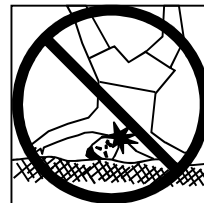

## INFORMATION ON USE OF THE TRAMPOLINE

Initially, get accustomed to the feel and bounce of the trampoline. The focus must be on the fundamentals of your body position and you should practice each bounce (the basic bounces) until you can perform each with ease and control.

### **To brake a bounce, flex your knees sharply before your feet come in contact with the mat.**

This technique should be practiced as you are learning each of the basic bounces. The skill of braking should be used whenever you lose balance or control of your jump. Always learn the simplest bounce first and be consistent with the control of your bounce before moving on to more difficult and advanced bounces. **A controlled bounce is when your take off point and landing point is the same spot on the mat.** If you move up to the next bounce without first mastering the previous, you increase your risk of injury. Do not bounce on the trampoline for extended periods of time as fatigue can increase your risk of injury. Bounce only for a brief period of time. Only one person should bounce on the trampoline at a time.

Jumpers should wear a t-shirt, shorts or sweats, and regulation gymnastics shoes, heavy socks, or be barefoot. If you are just beginning, you may want to wear long sleeve shirts and pants to protect against scrapes and abrasions until you master correct landing positions and form. Do not wear hard sole shoes, such as tennis shoes, on the trampoline as this will cause excessive wear on the mat. You should always mount and dismount properly in order to avoid injury. To mount properly, you should place your hand on the frame and step or roll up onto the frame, over the springs, and onto the trampoline mat. Always remember to place your hands onto the frame while mounting or dismounting. Do not step directly onto the frame pad or grasp the frame pad. To dismount properly, move to the side of the trampoline and place your hand onto the frame as a support and step from the mat to the ground. Smaller children should be assisted when mounting and dismounting.

Do not bounce recklessly on the trampoline as this will increase your risk of injury. The key to safety and having fun on the trampoline is control and mastering the various bounces. Never try to out-bounce another bouncer in terms of height! Never use the trampoline without supervision.

## **TRAMPOLINE PLACEMENT**

The minimum overhead clearance required is 26 feet (8 meters). Ensure that no hazards or obstructions are near the trampoline such as tree branches, swing sets, swimming pools,

electrical power wires, walls, fences, etc.

Please be aware of the following when selecting a place for your trampoline:

- ✘ Trampoline must be placed on a level surface
- ✘ The area must be well-lit.
- ✘ All obstructions from overhead, underneath or around the trampoline must be removed.
- ✘ Do not use this trampoline in-door
- ✘ Do not use this trampoline on any slippery floor surface, uneven or sloping ground surface
- ✘ Do not site trampoline on hard surfaces ,concrete etc. ,as this can damage the frame
- ✘ The trampoline must be well-fix on the ground to prevent moving when jumping.

You increase the risk of someone getting injured if you do not follow these guidelines.

**⚠ WARNING!**

