

The Vaulting Of 3-in-1 Plyometric Box

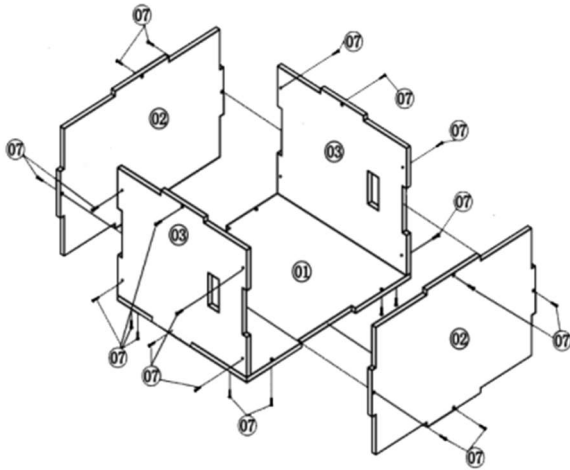

PART NO	DESCRIPTION	Q'TY
①	MAIN SUPPORT	2
②	Side 1	2
③	Side 2	2
④	SUPPORT 1	1
⑤	SUPPORT 2	1
⑥	SUPPORT 3	1
⑦	bolt	37

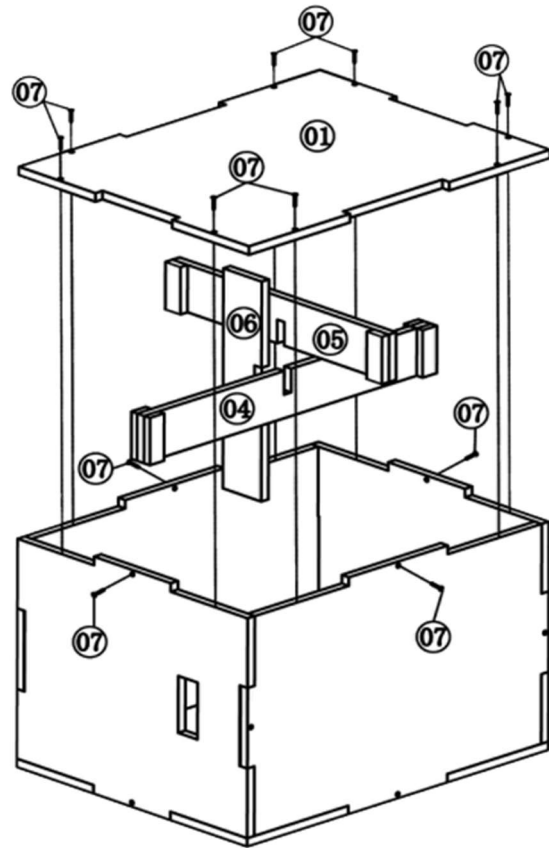

Assembly Instructions

Lay out all of the pieces and assemble the box without the center support to ensure you understand Where each piece connects. Next, assemble the center support as shown above. From here, you have two options:

Option 1) Add wood glue (not included) to the edges of the box pieces and re-assemble, inserting the center support before gluing the top (Part No 1). This provides extra strength for commercial gym environments or users over 120kg. Next, screw the box together.

Option 2) Insert the center support and screw the box together.